

Heart-Foot Pajarita

By Wensdy Whitehead

Recommended Paper: 3-6" (7.5-15cm) paper-backed foil or 6" (15cm) kami or thin duo.

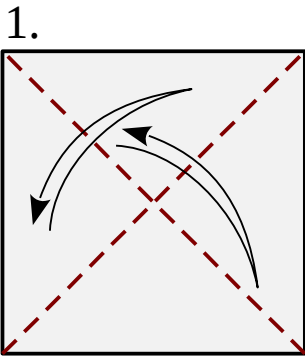
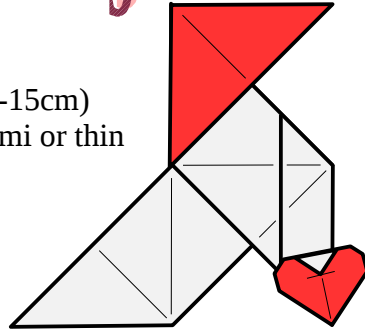

Fold and unfold.

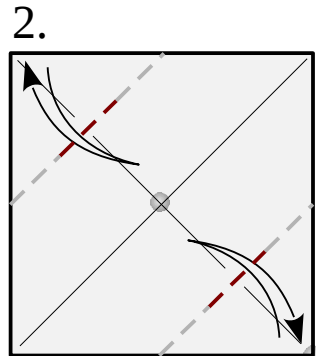

Bring the two (2) corners to the center and pinch across the diagonal.

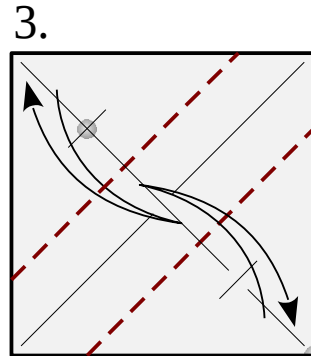

Fold each of the two (2) corners to the further pinch mark and unfold.

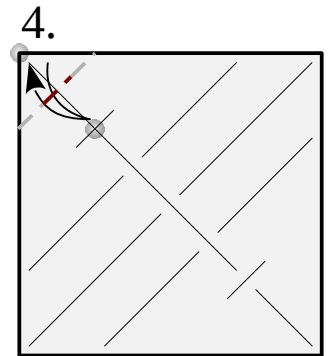

Bring one (1) corner to the nearest pinch for a new pinch across the diagonal.

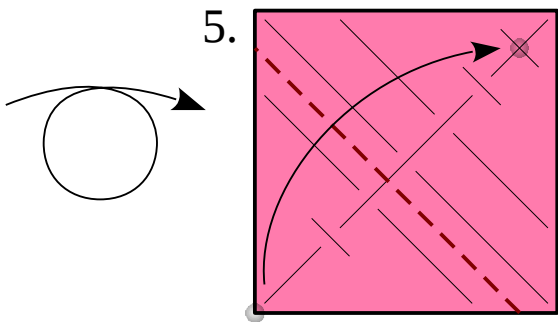

Fold the furthest corner to the newest pinch mark.

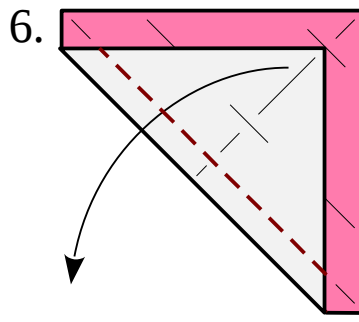

Refold the existing crease.

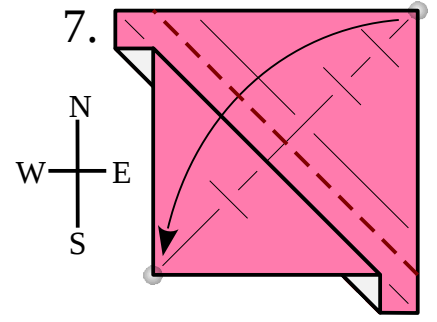

Fold the NE corner to the SW corner. Swapping roles may lose the existing pleat.

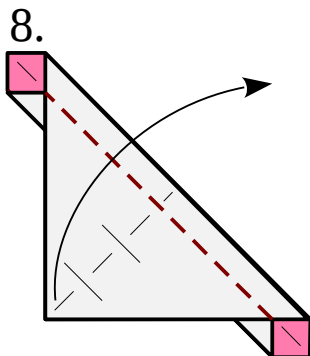

Refold the existing crease.

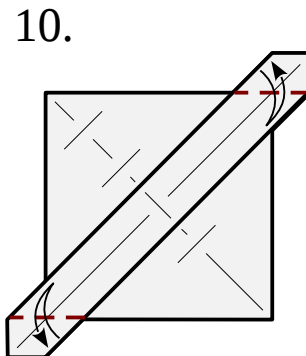
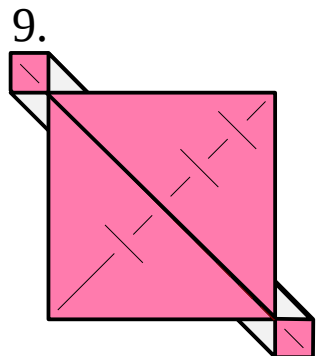

Fold along the color-change line on the other side. Unfold.

11.

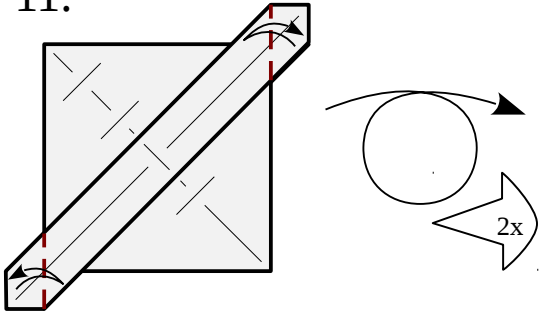

Fold along the other color-change line on the other side. Unfold.

12.

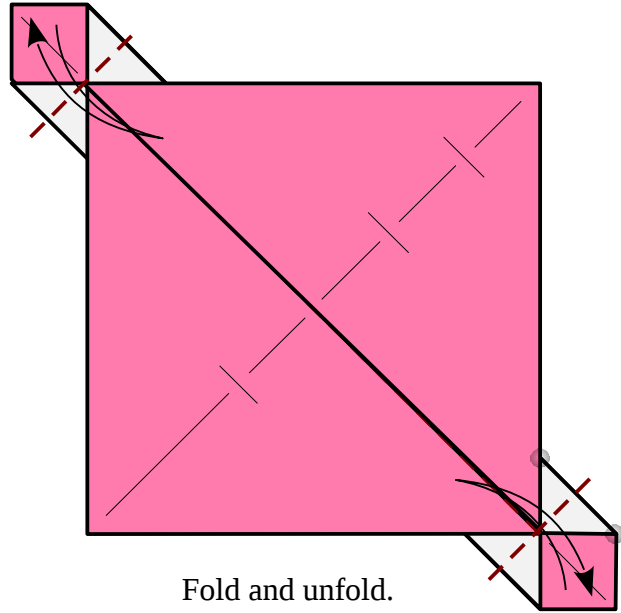

Fold and unfold.

13.

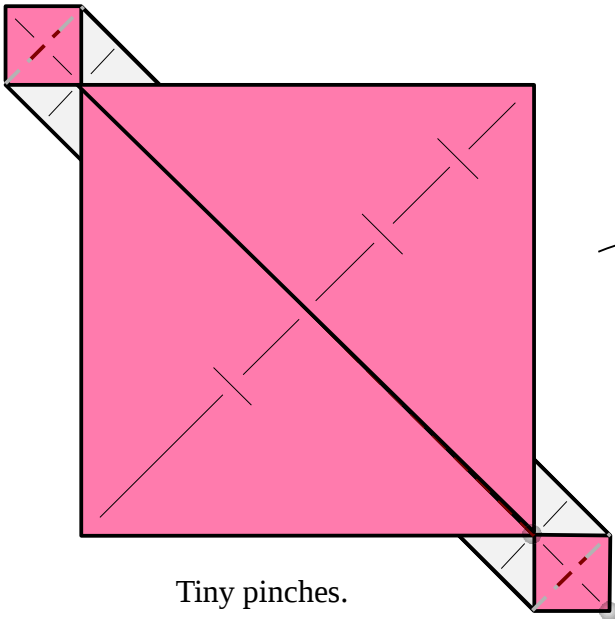

Tiny pinches.

14.

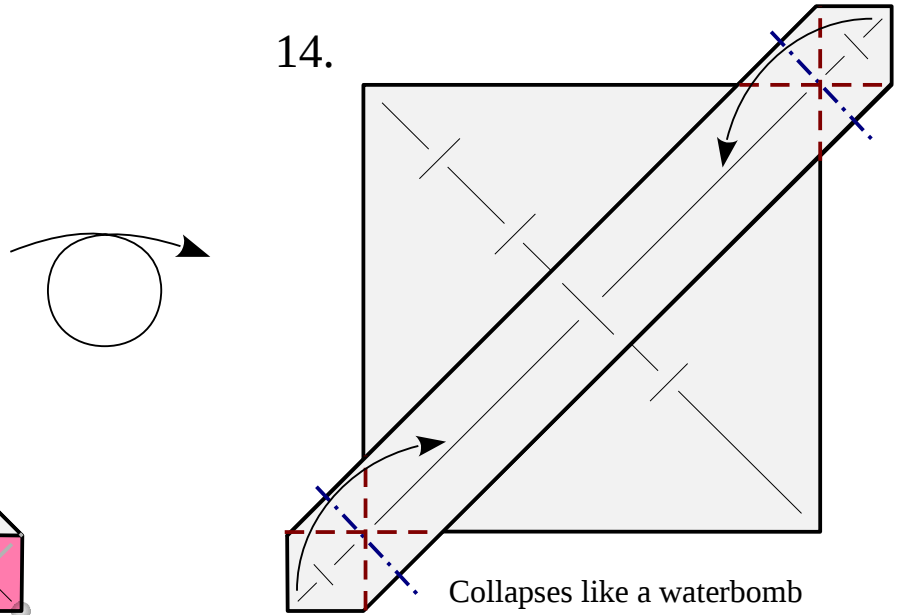

Collapses like a waterbomb or preliminary base.

15.

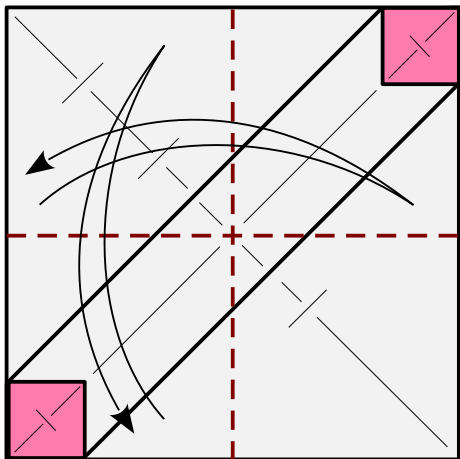

Fold and unfold.

16.

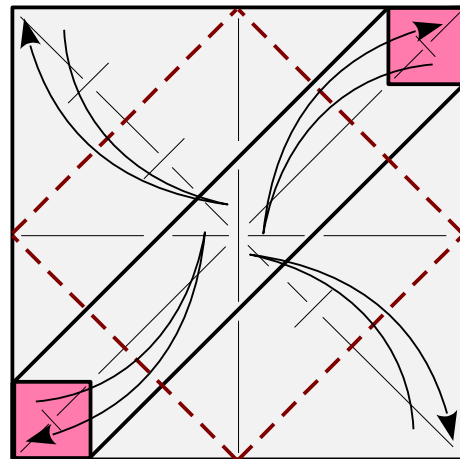

Blintz and unblintz.

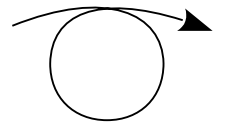

17.

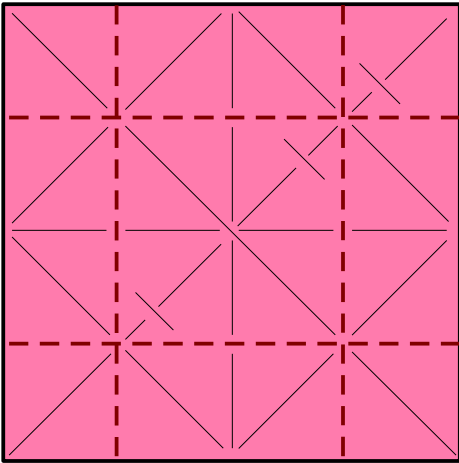

Pre-crease both pairs of cupboard doors.

18.

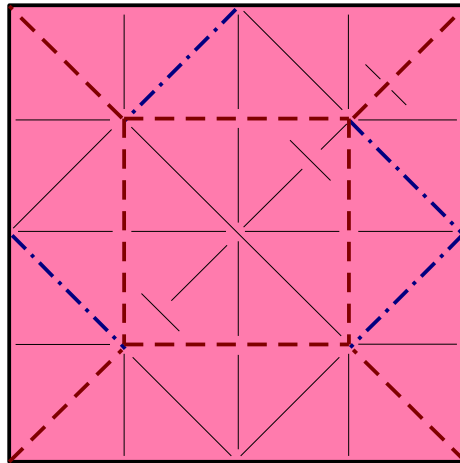

Collapse much like a windmill but not symmetrically. No new creases.

19.

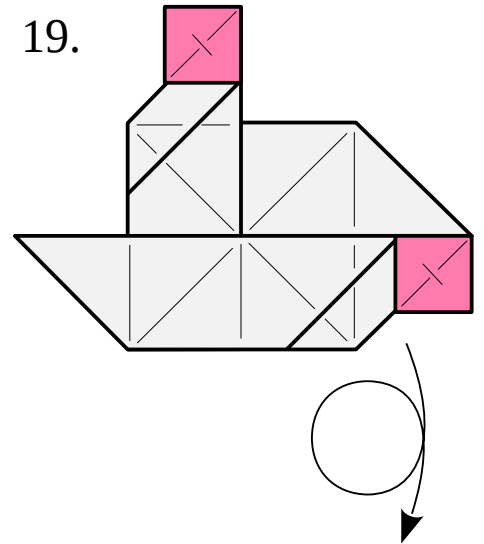

20.

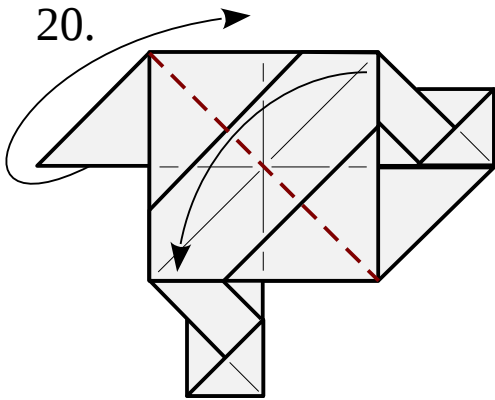

Page-turn,

21.

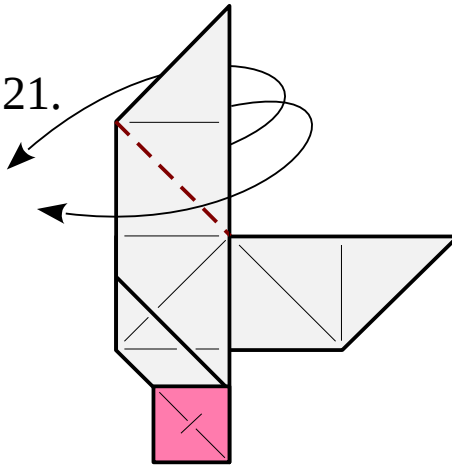

Outside-reverse fold.

22.

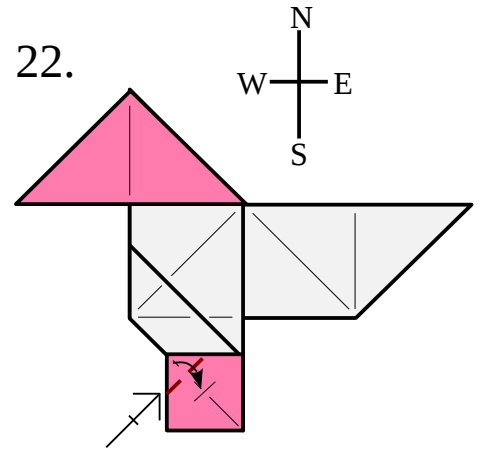

Start to shape the heart. Any of the four corners of the little colorful square can become the top of a heart, but the diagrams pick the NW corner. Fold to the pinched center of the square. Repeat behind.

23.

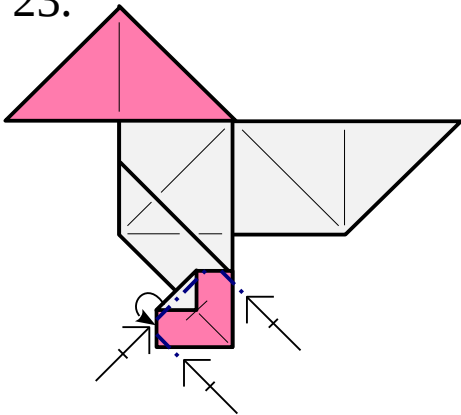

Tiny mountain folds to round the top and sides of the heart. Repeat behind.

24.

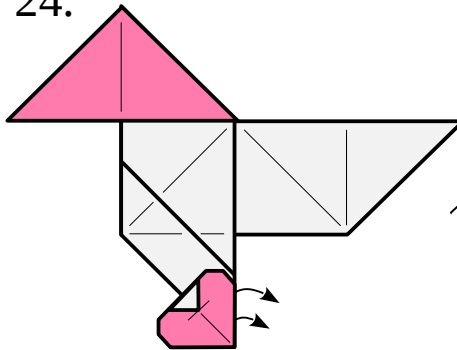

OPTIONAL: There is a bit of paper behind the heart that can take a bit of a squash to adjust the angle of the heart. Rotate to taste and repeat behind.

25.

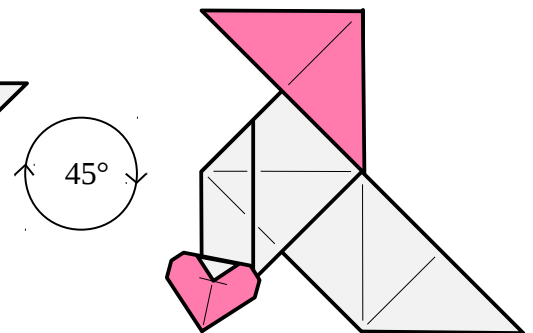

Done!