

Georgia

By Wensdy Whitehead

Recommended Paper: kami (thin with contrasting front and back).

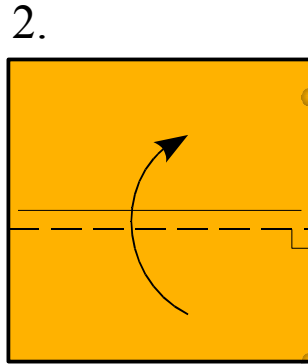
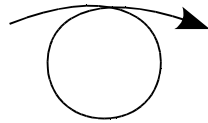
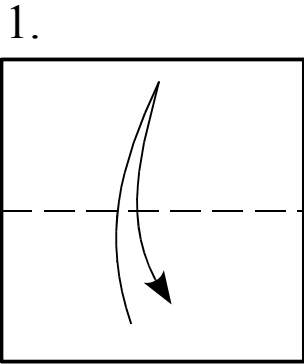

Fold almost to the far edge
(RAT fold perpendicular to
the edge.)

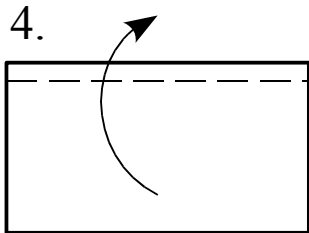
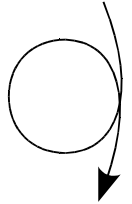

Restore the fold from
step 1.

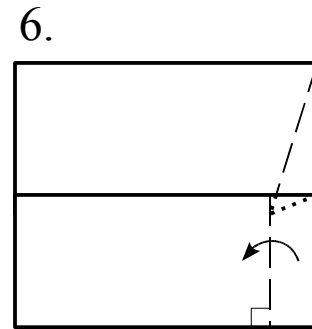
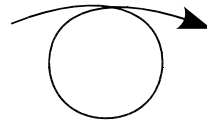

Fold the lower section and let it
pull the top section at an angle
so the top crease goes through
the corner. (RAT V-squash)

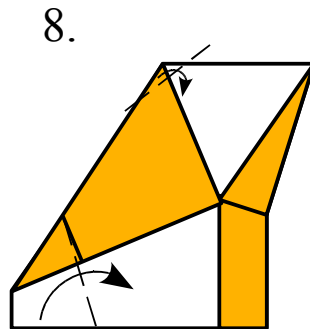
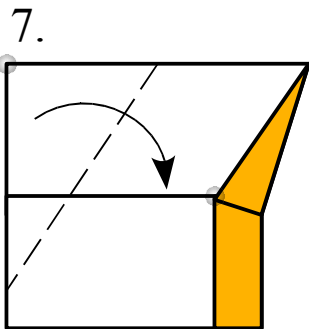

2 valley folds right
about there (RAT).

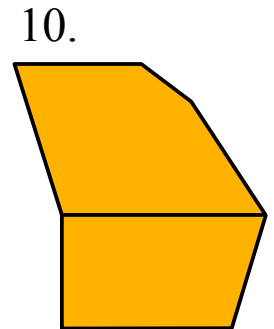
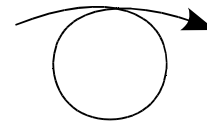
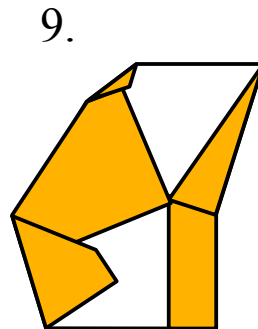

Done!